

Installation Guide

AC022K-BE-45S1 | AC022K-AE-45S1



Table of Contents

1. Safety	3
2. Packing List	5
2.1 Cable version	5
2.2 Soceket version.....	6
3. Product Overview	7
3.1 Cable version	7
3.2 Socket version.....	8
4. Specifications.....	9
5. Installation	11
5.1 Required Cable and Accessory.....	11
5.2 Required Tools	12
5.3 Installation Procedure.....	13
6. Load Balancing	17
6.1 Hardware Wiring.....	17
6.2 Software configuration.....	19
6.2.1 Introduction.....	19
6.2.2 Log In.....	19
6.2.3 Configure network for Charger.....	21
6.2.4 Load balancing.....	25
6.2.5 Set Maximum current	28
6.2.6 Choose Earthing system.....	28
6.2.7 Single or Three Phases Charging.....	29
7. Indicator.....	30
8. Troubleshooting	31
9. Routine Maintenance.....	32
10. Storage and Transportation	32
11. Disassembly	32
12. Disposal/Scrapping	32

About this manual

Thank you for choosing our charger.

This manual will guide you through the steps required to install, use, and maintain charger.

The guide is for reference only and does not constitute a warranty of any kind. The actual product (including but not limited to color, size, and functions) may vary. If this guide is inconsistent with the description on the official website, the latter prevails.



Some functions may be subject to change, according to the charger's latest software updates.

General symbols and signal words used in the document



With signal word 'Danger':

If you do not obey the instruction, this can cause death.



With signal word 'Warning':

If you do not obey the instruction, this can cause injury.



With signal word 'Caution':

If you do not obey the instruction, this can cause damage to the EVSE or to property.



With signal word 'Note':

A note gives more data or give some tips, to make it easier to do the steps.

1. Safety



- Do not install or use the product in or near areas with flammable, explosive, chemical materials, or steam.
- Before installing or cleaning the product, switch off the upstream residual current operated circuit-breakers with integral over current protection (RCBO) of it.
- Do not use or replace the product in extreme weather conditions.
- Do not remove the safety marks, warning signs, nameplates, or cabling marks from the product.
- Do not spray water or any liquids on the product.
- Keep children and pets away from the product.
- Do not disassemble, repair, or modify the product on your own; instead, by a certified or qualified professional.
- When installing the product, install the ground cable first. When uninstalling the product, remove the ground cable last. Do not work on the product in the absence of a properly installed ground cable.
- Do not install or remove power cables with power on. Before switching on the upstream RCBO, ensure that cables are correctly connected to the charger.
- Use cables that comply with local regulations and ensure that the insulation layer is intact.
- Seal unused power cable holes with cable rubber cover after the installation is complete.
- Do not fold or crush any component of the product, or damage it with sharp objects.
- Do not use the product if it is defective, cracked, damaged, or malfunctioned.
- A generator cannot serve as the power supply for the product.
- Do not connect the product to devices other than a vehicle.
- Cord extension sets are not allowed to be used.
- Do not insert your fingers or sharp objects into an components of the product.

- Radio waves generated by the product may affect normal operation of implanted medical appliances or personal medical appliances, such as the pacemakers, cochlear implants, and hearing aids. Consult the manufacturer of your medical equipment for more information.



- Ensure that the installation surface is solid enough to hold the charger. It is recommended that the wall have a bearing capacity of at least 100 kg.
- Ensure that the wall is flat and reserve sufficient space around the installation position to ensure good ventilation.
- Ensure that the wall is larger than the rear cover of the charger.
- When installing the product, use a screwdriver with a proper torque to tighten the screws.
- When routing power cables, ensure that there is no coiling or twisting.
- Do not join or weld power cables. If necessary, use a longer cable.
- Do not install or use the product in an environment with strong magnetic fields or near a wireless transmitter.











- Do not use third-party cables or adapters.
- Do not drop, squeeze, or pierce the product to avoid device faults.
- Before charging your electric or hybrid vehicle, turn off the car.





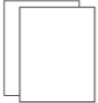

2. Packing List

Upon receipt of your shipment, kindly verify the contents against the packing list. Should any items be absent, do not hesitate to reach out to us without delay.

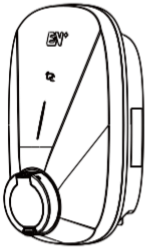
2.1 Cable version

Item	Icon	Quantity
 <p data-bbox="132 1086 311 1114">Ev charger (x1)</p>		5
		1
		2
		6
		1
		1
		1
		1

2.2 SoCKET version

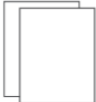
	Item	Icon	Quantity
 <p data-bbox="134 774 311 801">Ev charger (x1)</p>	Cord end terminal		5
	Positioning diagram		1
	RFID card		2
	M3*12 Screw		7
	Mounting bracket		1
	L-shaped wrench		1
	Installation guide		1

3. Product Overview

3.1 Cable version

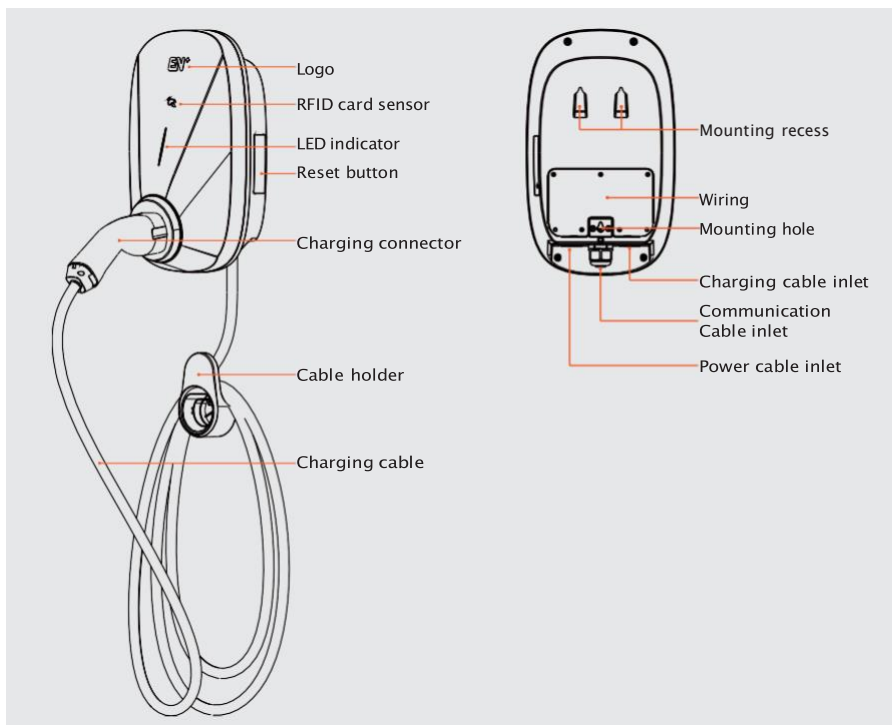

Dimensions

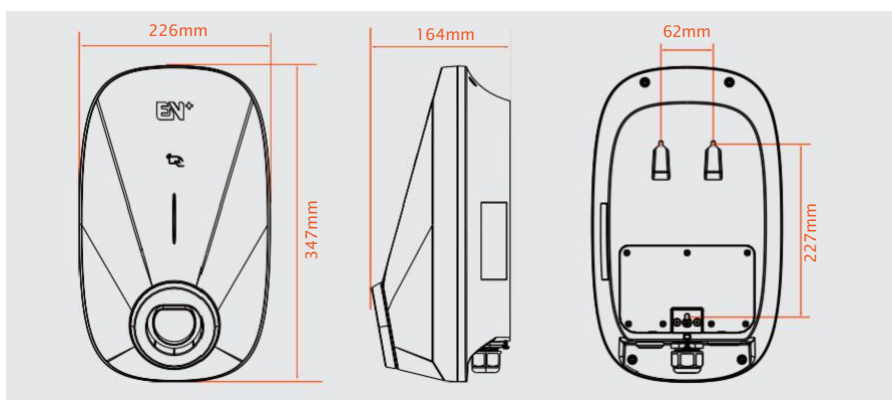

3.2 Socket version

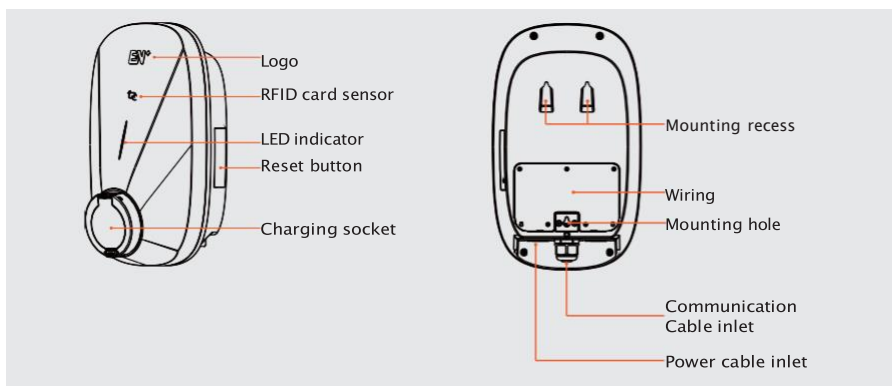

Dimensions

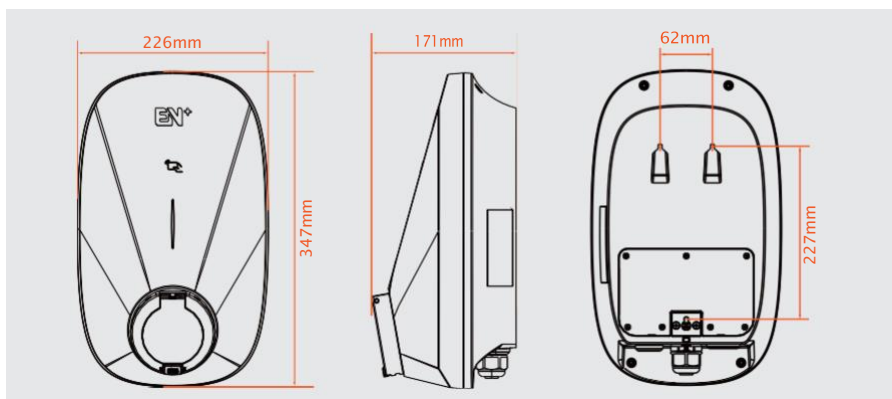

4. Specifications

Product Model		AC022K-BE-45S1 AC022K-TE-45S1	AC7022K-AE-45S1
Electric specification	Power Supply	3P+N+PE	
	Rated Voltage	400V AC	
	Rated Current	32A	
	Frequency	50/60 Hz	
	Rated Power	22kW	
	Charging Mode	Mode 3	
Classic attributes	Charge Connector	Type 2/ T2S Socket	Type 2 Cable
	Cable Length	/	7m (optional)
	Enclosure	PC	
	Installation	Wall-mounted/Pedestal-mounted (optional)	
	LED Indicator	Green/Yellow/Red	
Communication	Wi-Fi	Frequency Bandwidth:802.11 b/g/n 2.4 GHz (2412-2472 MHZ) Max RF Output Power:<20dBm (-10dBW)	
	Ethernet	Support	
	Bluetooth	Bluetooth Low Energy (BLE 4.1)	
	4G	Optional	
	OCPP	OCPP 1.6 Json	
Working environment	Applicable Scenario	Indoor /Outdoor	
	Working Temperature	-30℃ to +50℃	
	Working Humidity	5%~95%	
	Working Altitude	<2000m	
	Pollution Degree	PD3	

Safety	RCD	30mA AC + 6mA DC	
	IP Rating	IP55	IP65
	Impact Protection	IK10	
	Electrical Protection	Over current protection, Residual current protection, Surge protection, Over/Under voltage protection, Over/Under frequency protection, Over temperature protection	
	Certification	CE, RoHS, Reach	
	EMC Class	CC25:G25class B	
	Type of Protection Against Electric Shock	Class I equipment	
	Grounding Support	TN/ TT/IT(optional)	
	Standard Compliance	EN IEC 62311:2020/EN IEC 61851-1:2019/EN 301489-1 V 2.2.3:2019 EN 301489-3 V 2.1.1:2019/EN 301489-17 V 3.2.4:2020/EN IEC 61000-6-1:2019 EN 61000-6-3:2007+A1/EN IEC 61000-3-2:2019/EN 61000-3-3:2013+A1 EN IEC 61851-21-2:2021/EN 300328 V 2.2.2:2019/EN 300330 V 2.1.1:2017 IEC 62955:2018 IEC 62321	
	Warranty	2 Year	

5. Installation

Before the installation, ensure that:

- The charger power is within the allowed load range of the place.
- Cables and RCBOs meet the installation and usage requirements.
- If the AC input power cable exposed to the outdoor environment is 3m or longer, consult the local installer. You are advised to install a surge protective device (SPD) at the upstream of the charger's RCBO.
- A network cable that is long enough is prepared if the charger is connected to a wired network.
- The installation area should be covered by a wireless network if the charger is connected to the network through WiFi.

5.1 Required Cable and Accessory

Before installation, you will need to prepare the following accessories and cables on your own:











To facilitate cabling, aluminum wires and solid copper wires are not recommended.



Ethernet cable, RJ45 connector, and RS485 cable are necessary solely for the implementation of their respective functions.

Item	Specification
Power cable	Operating current: 32A Cross section area: 6mm ²
RJ45 connector	8P
Ethernet cable	Cat 5e or higher, CSA: 0.2 ~0.25mm ²
RCBO	4P RCBO, C40, 40 A (50 A is recommended if the ambient temperature is higher than 45°C), Type A, in compliance with local regulations.
RS485 cable	22 to 24AWG shielded twisted pair
Cable tie	Width: 2.5mm to 4mm; Length: ≥ 200mm

5.2 Required Tools

Tool	Icon	Function
Tape ruler		Measure the installation height
Electric screw driver		Fasten the screws
Hammer		Drive the wall plugs into the wall
Wire stripper		Strip the wire
Multimeter		Check the voltage and current
Level (> 180mm)		Keep the charger level
Marker		Make marks on the wall
Electric drill		Drill holes on the wall
Wire cutter		Fasten the gland
Crimping pliers		Clamp cord end terminal
Hydraulic clamp		Clamp the RJ45 connector

5.3 Installation Procedure

1 Recommended installation height

Socket version

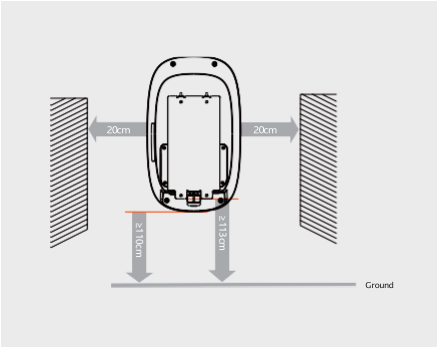

Cable version

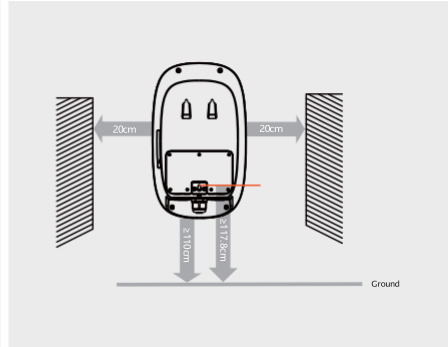

2 Wiring



Please note that the wirings for both socket version and cable version are identical.

IT system is optional.

The following cables comply with the IEC 60446 standard. Cable colors may vary according to different regions.

Connect power cables based on the actual phase condition.

TN and TT systems are configured with neutral conductors. IT systems do not have neutral conductors.

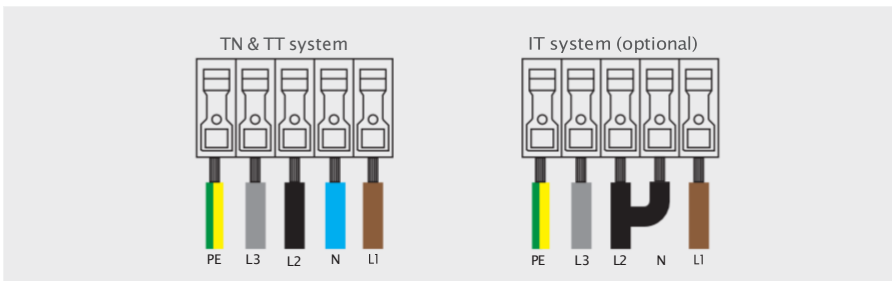

For IT system, the L2 and N needs to be short-circuited, and if a RCBO is installed, L2 and N needs to be short-circuited at the input side the of RCBO.

There are two methods to connect the power cable :

 No matter which connection method you use, ensure that the length of the wire is stripped adequately to prevent contact issues. When using a wire ferrule, stripe the wire to exactly 20mm; without a ferrule, stripe the wire to 18mm for optimal contact.

- With wire ferrules

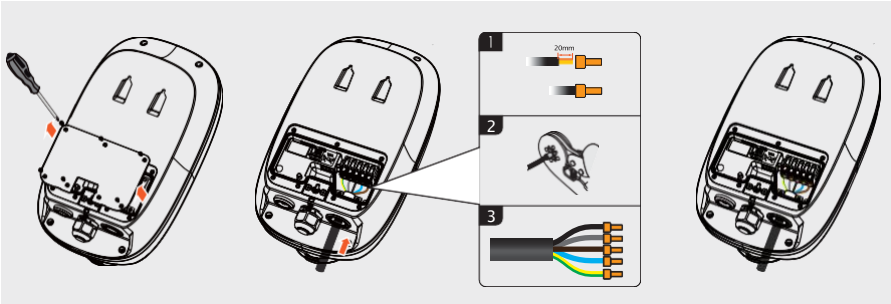

- Without wire ferrules

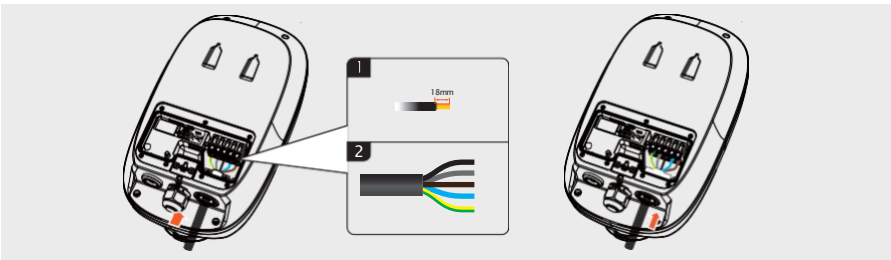

 Please note that the following step 3 and 4 are not mandatory; they are only required when you need to implement the corresponding function.

3 Connect RS485 cable and CT

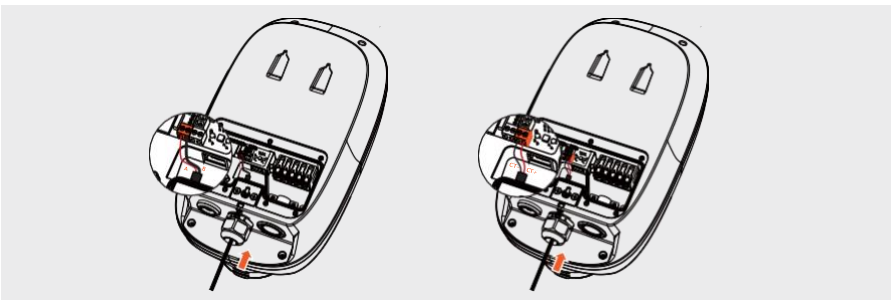

4 Connect Ethernet cable & Insert SIM card

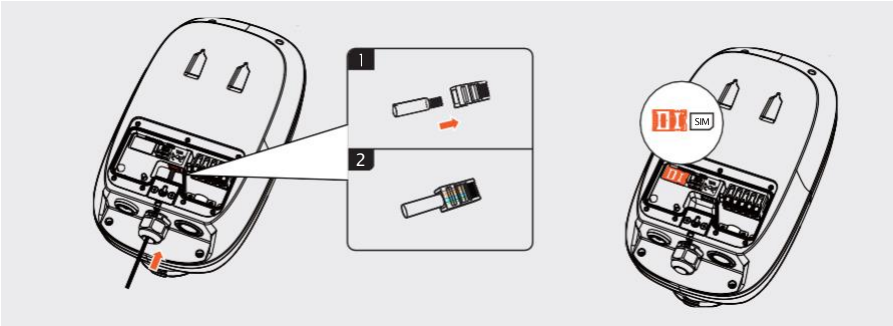

5 Install charger (socket)

Install the back plate

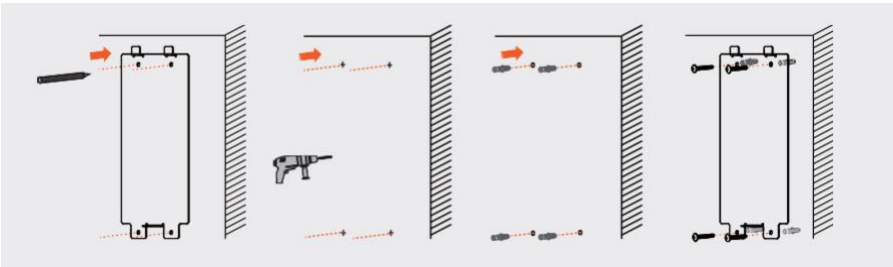

Secure the charger to the back plate

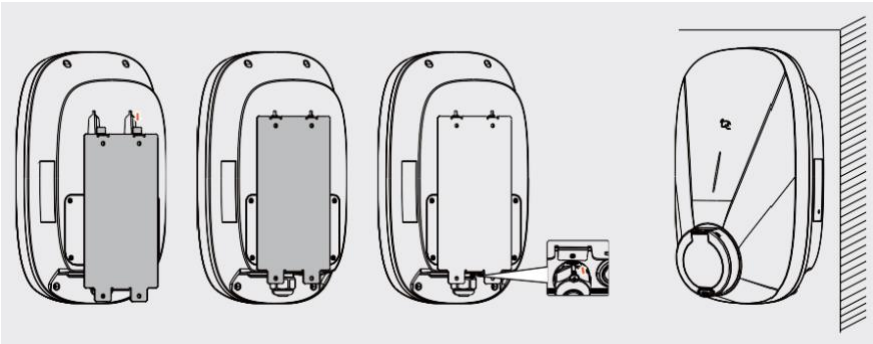

6 Install charger (cable)

Drill holes, insert wall plugs and screws

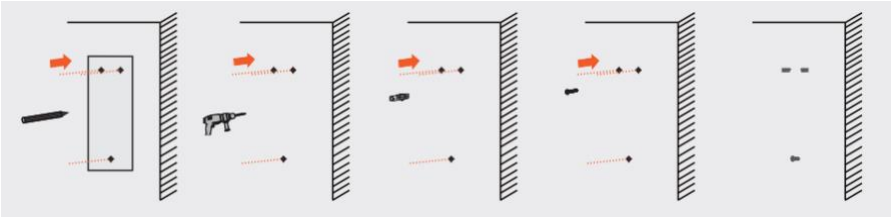

Secure the charger to the wall-mounting screws

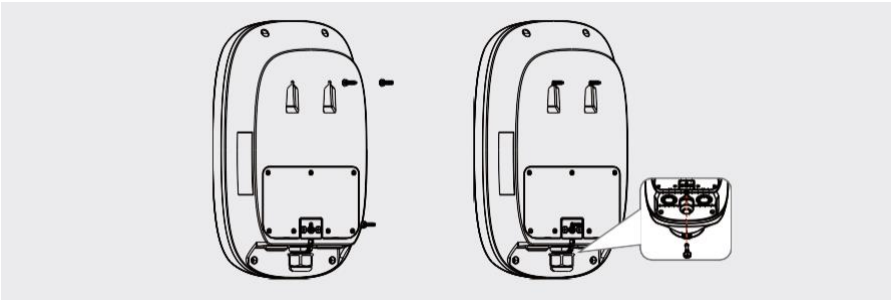

Install cable holder

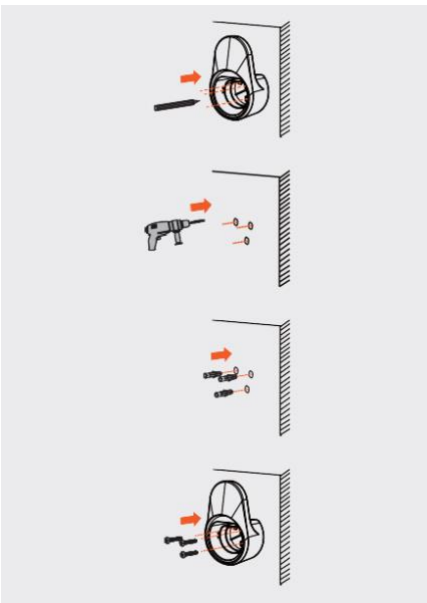

Installation completed

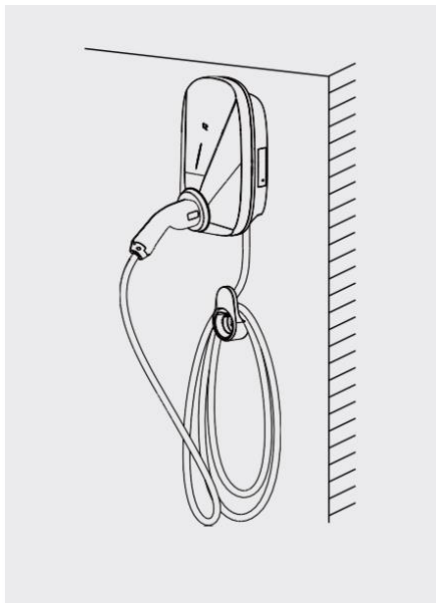

6. Load Balancing

The charger is equipped with load balancing management and photovoltaic (PV) charging capabilities. Both of these charging modes require proper hardware wiring and corresponding software configuration to function effectively.

Here are the two charging solutions available:

Meter Only Configuration: This setup utilizes a meter to manage the charging process, ensuring efficient energy distribution.

Meter with Current Transformer (CT) Configuration: This advanced setup combines the use of a meter with three current transformers to provide more precise control over the charging current, enhancing the charging efficiency.

6.1 Hardware Wiring

• Meter Only Configuration

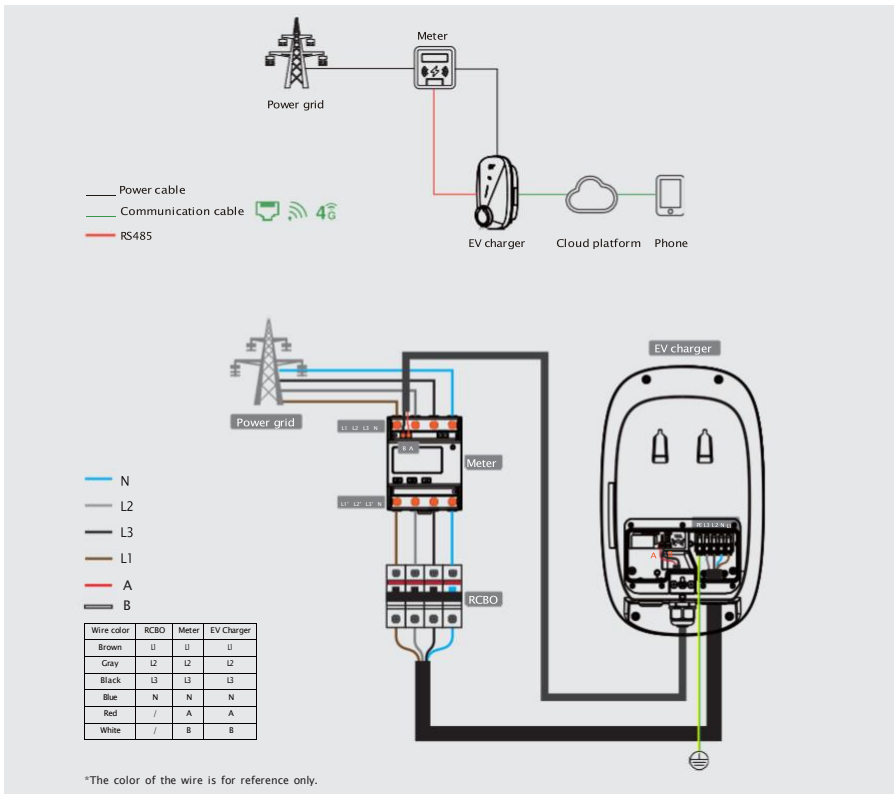

Meter with Current Transformer (CT) Configuration

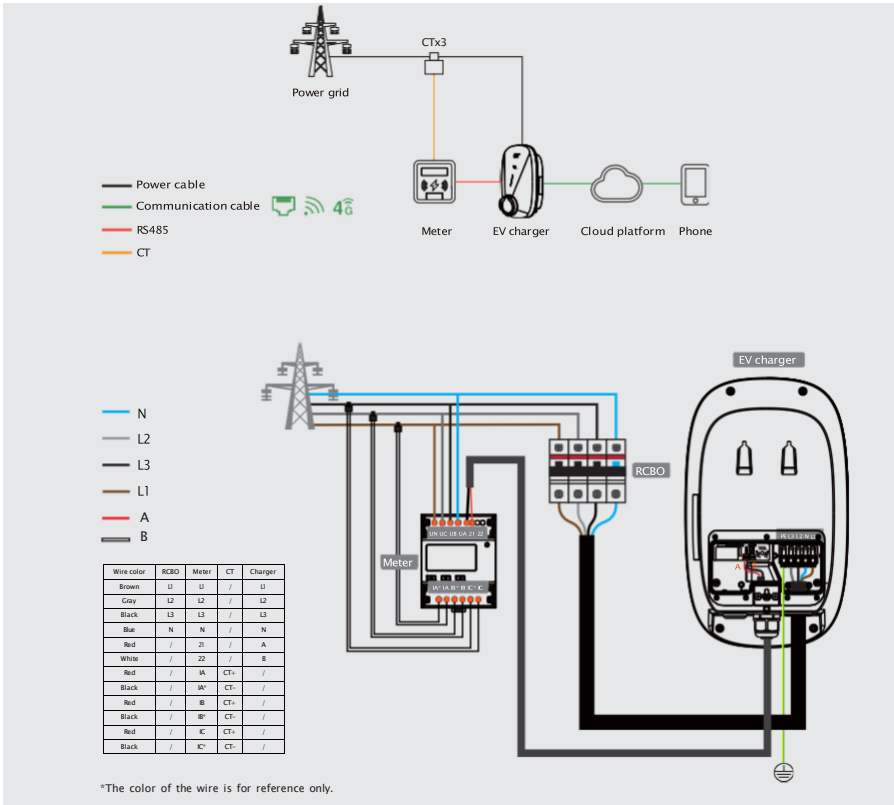

Please note that the meter and CT are sold separately.

6.2 Software configuration

6.2.1 Introduction

AP Mode, also known as Access Point Mode, is a versatile wireless networking feature that enables devices like EV charger to function as Wi-Fi access points, establishing a dedicated hotspot. Users can effortlessly connect their smartphones or other mobile devices to this hotspot and manage the device through a web interface by navigating to a designated IP address, such as 192.168.4.1. This setup facilitates remote monitoring and configuration of the device, eliminating the need for physical interaction and ensuring a user-friendly and secure wireless management experience.

Before operation you need to know

- *After completing a configuration or settings, upon clicking 'Save' or 'Confirm', the charger will automatically restart, thereby disconnecting the hotspot. At this time, you are required to wait for 30 seconds following the charger's restart, then short press the reset button to initiate the charger's hotspot and ensure reconnection to the charger's hotspot on your mobile device before proceeding with further operations.*
- *Upon initial login, you will be required to change password. If you forget the new password, you can press the "Reset" button and hold on for 5s to restore the password to its original default one.*

6.2.2 Log In

1. Make sure that the WLAN is turned on.
2. Press the reset button to activate the hotspot of the charger (the hotspot remains available for 15 minutes only).
3. Locate the charger's Wi-Fi hotspot (wifi name: the serial number of the charger) in your phone's WiFi list.
4. Enter the password to connect the charger to your phone (a dedicated password is 8-digit depending on the SN of the charger which is case sensitive and can be found on the last page of this manual).
5. To access the Login page of AP mode, enter the IP address 192.168.4.1 in a browser, followed by the 4-digit password: a PIN number, which can be found on the last page of this manual.

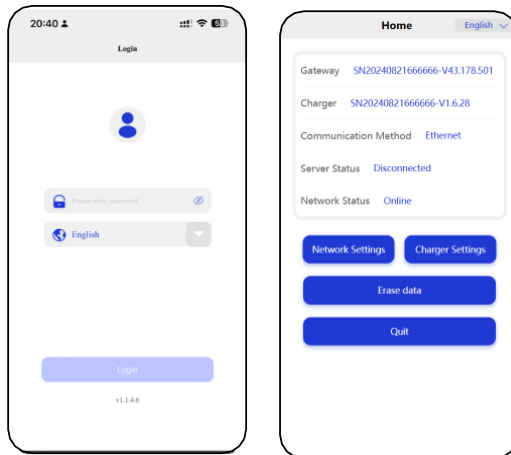

! For password, you will be prompted to change it after logging in. If you change the password but forget it later, please press the reset button on to return the password to the initial value.

! Your charger will automatically restart once the network configuration is complete, ending communication between your phone and the charger. At this point, your phone may automatically join other WiFi hotspots, preventing you from accessing the network configuration page. As a result, before accessing the network configuration page, please ensure that your phone is connected to the WiFi hotspot of the charger.

6.2.3 Configure network for Ch6rger

There are three networking mode for you to choose: Wi-Fi, 4G, and Ethernet.



Configuring the network is a prerequisite for you to carry out subsequent operations.

Tap here to access the network configuration page

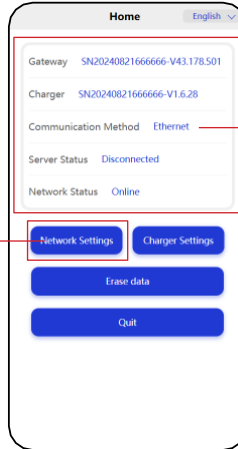

The basic status of the network connection

- **Use 4G for communication**

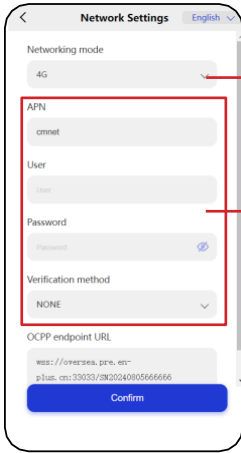
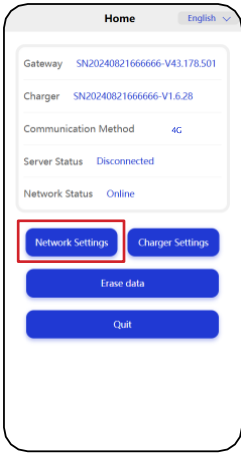
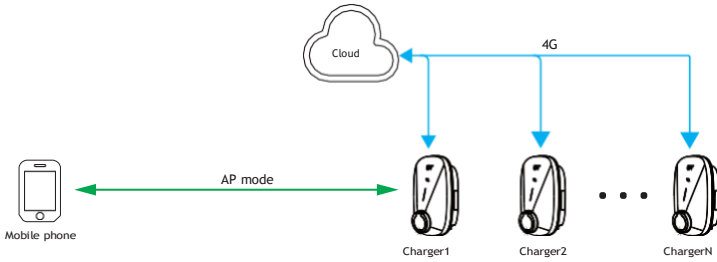

Choose 4G

The SIM card information

The URL address address that connects your charger to a cloud management platform

- **Use WiFi for communication**

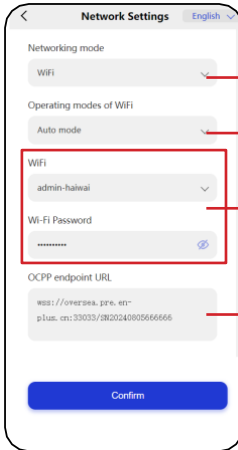
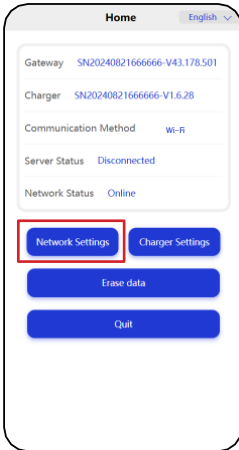
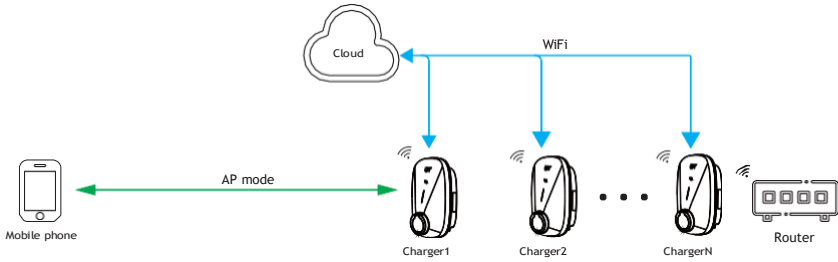

Choose WiFi

Keep default

WiFi information your charger needs to be connected

The URL address that connects your charger to a cloud management platform

- **Use Ethernet for communication**

If you choose Ethernet to configure network for your charger, there are two options for IP address configuration:

- Static IP
- DHCP

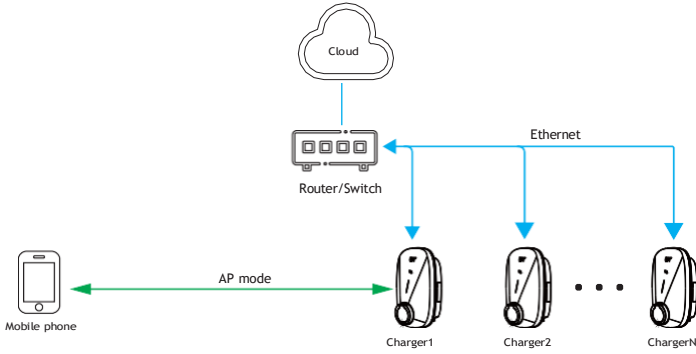

Static IP

The image shows two screenshots of a mobile application interface. The first screenshot is the 'Home' screen, displaying various status information like Gateway, Charger, and Network Status. A red box highlights the 'Network Settings' button. The second screenshot is the 'Network Settings' screen, where 'Networking mode' is set to 'Ethernet' (labeled 'Choose Ethernet'), 'IP address configuration' is set to 'Static IP' (labeled 'Choose static IP'), and the 'IP address' field is set to '192.168.192.120' (labeled 'The IP address of the charger'). The 'Gateway address' is set to '192.168.192.1' (labeled 'The local networking information'). Other fields like 'Subnet mask' and 'DNS address' are also visible. A 'Confirm' button is at the bottom.

DHCP

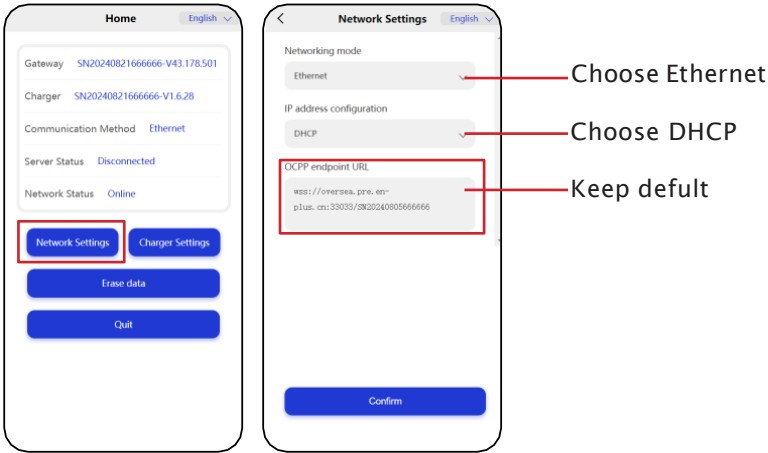

! Choosing static IP for IP address configuration is recommended.

6.2.4 Load balancing

There are multiple options to configure the load balance in a commercial scenario, the classifications as shown below:

- **Load balancing by meter**

In a scenario where the maximum current capacity is less than 80A, you can achieve load balancing by connecting meter to your EV charger.

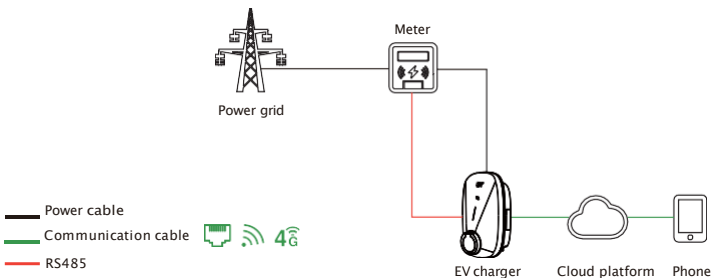

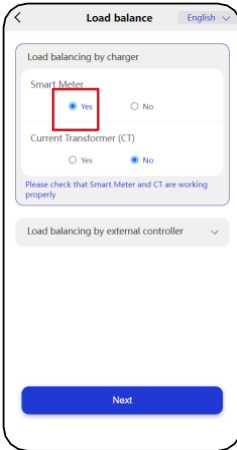
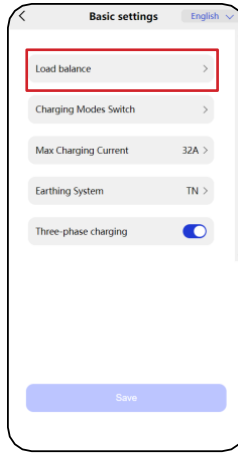
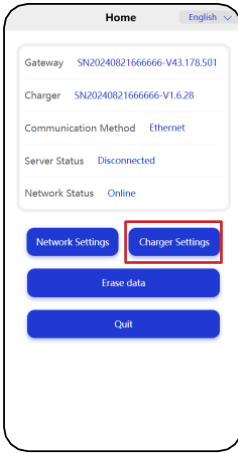

The tripping threshold of the current

- **Load balancing by meter + CT**

In environments characterized by high electrical currents, the meter's inherent detection range limitations can be transcended by integrating three current transformers (CT). By connecting the CT to both the electrical grid and your EV charger, you effectively expand the current detection capabilities, facilitating dynamic load balancing. The standard detection range is robust, spanning from 0 to 100 A, ensuring comprehensive monitoring and management of high current loads.

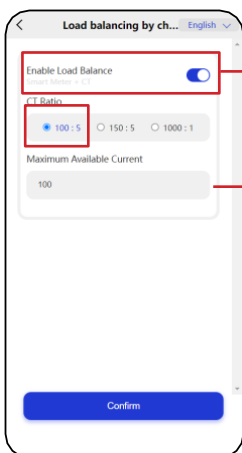
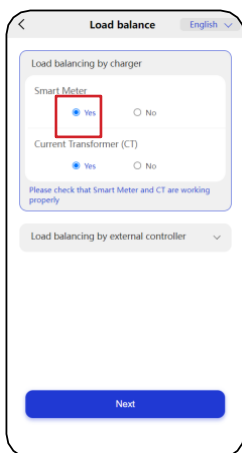
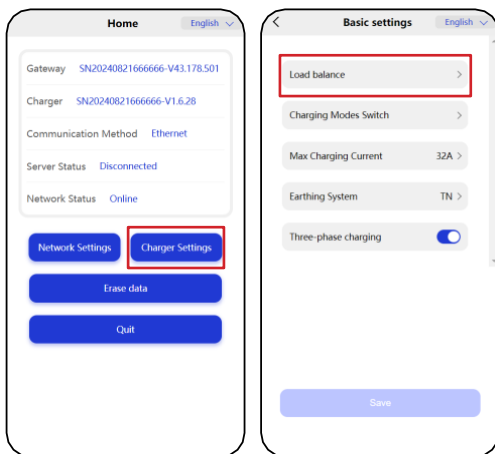
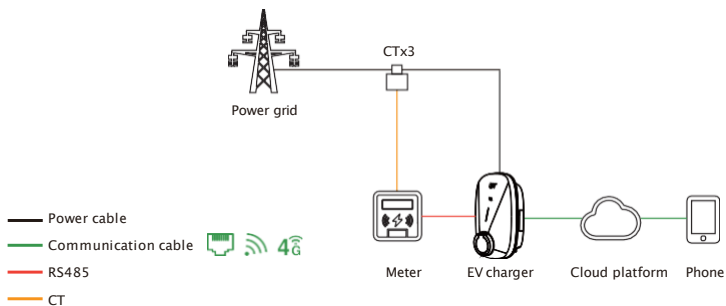

Turn on

The tripping threshold of the current

6.2.5 Set Maximum current

Set the maximum current to charge the electric vehicle.

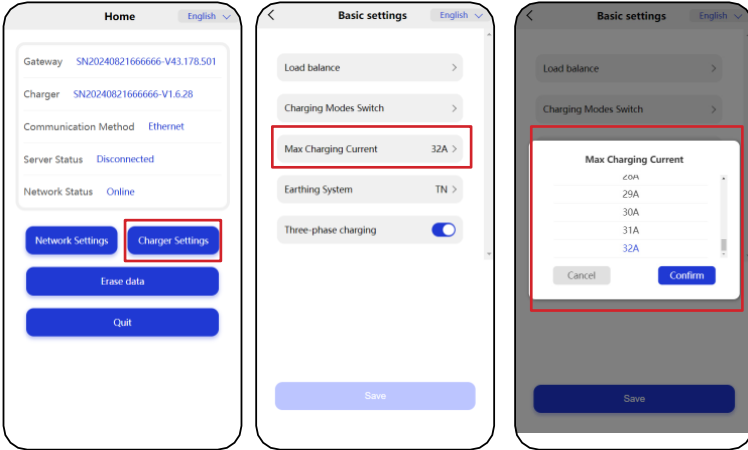

6.2.6 Choose Earthing system

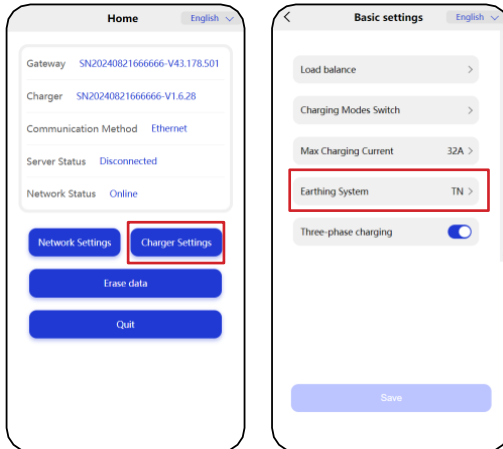

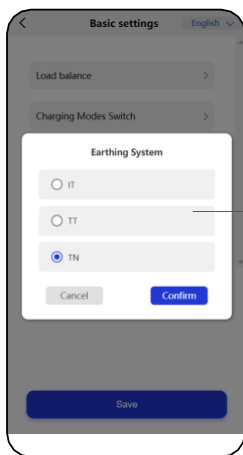

Based on the actual earthing system supported locally

6.2.7 Single or Three Phases Charging

Turning on this toggle will enable the charger to charge the vehicle at a three-phase rated power of 22kW; turning of this toggle will enable the charger to charge the vehicle at single-phase power of 7kW.

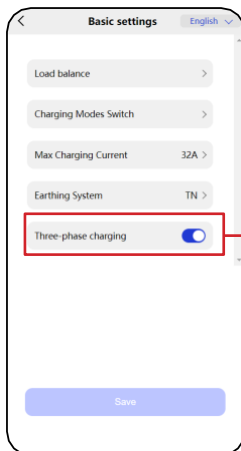
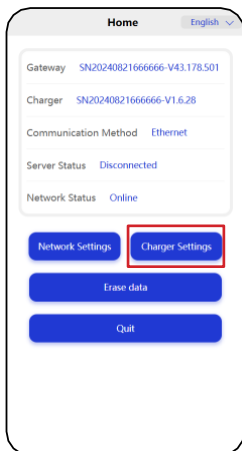

Turn on

7. Indicator

Indicator color	Indicator status	Charger status
Green	Cycle: flash slowly (on for 1s then off for 3s)	Charger standby
	Cycle: flash green twice (on for 200ms and off for 1000ms), then off for 3000ms	Charger started successfully, and wait for EV's response
	Cycle: flash green five times (on for 200ms and off for 1000ms), then off for 3000ms	Charging connector plugged
	Fade in and out at intervals of 1s	Charging in progress
	Steady green	Charging ended
Yellow	Steady yellow	Warnings
	Cycle: flash yellow five times (on for 200ms and off for 1000ms), then off for 3000ms.	Insufficient power allocated, charging suspended
	Cycle: flash yellow for up to five times (on for 100ms and off for 100ms).	Successful card swiping
	Cycle: flash green and flash yellow alternately for 1s then off for 3s	No network/Not connected to the server
Red+ Yellow	Flash red/Steady red Flash red and yellow	Faulty
White	Fade in and out at intervals of 1s	Self-test upon power on
	Cycle: flash white five times (on for 200ms and off for 1000ms), then off for 5000ms	Firmware upgrading

8. Troubleshooting

Indicator color	Charger status	Indicator status
Red	Relay adhesion	Steady red
	Leakage current	Cycle: flash red once then off for 3s
	CP fault	Cycle: flash red twice then off for 3s
	Over current	Cycle: flash red three times then off for 3s
	Input wires are connected reversely	Cycle: flash red four times then off for 3s
	Leakage current loop is abnormal	Cycle: flash red five times then off for 3s
	Input terminals over temperature	Cycle: flash red six times then off for 3s
	Relay over temperature	Cycle: flash red seven times then off for 3s
Red + Yellow	Over/under voltage	Cycle: stay yellow for 2s then flash red once then off for 3s
	Over/under frequency	Cycle: stay yellow for 2s then flash red twice then off for 3s
	Meter communication is abnormal	Cycle: stay yellow for 2s then flash red three times then off for 3s
	Smart Meter communication is abnormal	Cycle: stay yellow for 2s then flash red four times then off for 3s
	Charging connector lock abnormal	Cycle: stay yellow for 2s then flash red six times then off for 3s
	Charging connector current abnormal	Cycle: stay yellow for 2s then flash red seven times then off for 3s

White	BOOT security verification failed or the security chip failure	Cycle: flash twice (on for 200ms and off for 1000ms for) then off for 5000ms
-------	--	--

9. Routine Maintenance

Chargers do not need special maintenance. You are advised to check and clean the enclosure of the charger and accessories such as the charging connector every six months.

Check whether the charger and cables are damaged.

Use a dry cloth to clean the surface of the charger. Do not spray water directly on the charger.



Do not use corrosive cleaners, glass cleaners, or organic solvents.

10. Storage and Transportation

Chargers should be transported in the original packages. Do not place other objects on the top of the charger.

Before transportation, store the product in a clean, dry, and well ventilated place with a relative humidity of not more than 80% and free from corrosive gases.

The environmental specifications for storage and transportation shall not go beyond those specified in the Technical Specifications.

11. Disassembly

Only authorized and qualified electricians are allowed to disassemble the product.

Power off the charger before disassembling it. Disassemble a charger in the reverse order of installation.

12. Disposal/Scrapping

The product should be disposed of at recycling points for electronic equipment. Dispose of the product in a correct and environmental friendly manner in compliance with local laws and regulations.

Electronic devices cannot be disposed of as household waste.

PIN CODE

