

Installation Guide

NANO DUAL CHARGER

Table of Contents

1. Safety	1
2. Accessories	3
3. Product overview	4
4. Installation	8
5. Configure network for the charger	16
6. Evchargeo Cloud platform	20
7. App installation	20
8. Web-based payment	20
9. Indicator	21
10. Troubleshooting	22
11. Load balancing	23
12. Routine maintenance	23
13. Storage and transportation	23
14. Disassembly	23
15. Disposal/Scrapping	24

About This Manual

Thank you for choosing our Nano dual charger.

This manual will guide you through the steps required to install, use, and maintain Nano dual charger.

The manual is for reference only and does not constitute a warranty of any kind. The actual product (including but not limited to color, size, and functions) may vary. If this manual is inconsistent with the description on the official website, the latter prevails.



Some functions may be subject to change, according to the charger's latest software and app updates.

General symbols and signal words used in the document



With signal word 'Danger':

If you do not obey the instruction, this can cause injury or death.



With signal word 'Warning':

If you do not obey the instruction, this can cause injury.



With signal word 'Caution':

If you do not obey the instruction, this can cause damage to the EVSE or to property.



With signal word 'Note':

A note gives more data or give some tips, to make it easier to do the steps.

1. Safety



1. Do not install or use the product in or near areas with flammable, explosive, chemical materials, or steam.
2. Before installing or cleaning the product, switch off the upstream residual current operated circuit-breakers with integral over current protection (RCBO) of it.
3. Do not use or replace the product in extreme weather conditions.
4. Do not remove the safety marks, warning signs, nameplates, or cabling marks from the product.
5. Do not spray water or any liquids on the product.
6. Keep children and pets away from the product.
7. Do not disassemble, repair, or modify the product on your own; instead, by a certified or qualified professional.
8. When installing the product, install the ground cable first. When uninstalling the product, remove the ground cable last. Do not work on the product in the absence of a properly installed ground cable.
9. Do not install or remove power cables with power on. Before switching on the upstream RCBO, ensure that cables are correctly connected to the charger.
10. After the upstream RCBO is switched on, do not touch the terminals on the back plate directly or with conductors.
11. Use cables that comply with local regulations and ensure that the insulation layer is intact.
12. Keep cables at least 30 mm away from heat-generating components or heat source areas.
13. Seal unused power cable holes with cable rubber cover after the installation is complete.
14. Do not fold or crush any component of the product, or damage it with sharp objects.
15. Do not use the product if it is defective, cracked, damaged, or malfunctioned.
16. A generator cannot serve as the power supply for the product.
17. Do not connect the product to devices other than a vehicle.
18. Cord extension sets are not allowed to be used.
19. Do not insert your fingers or sharp objects into an components of the product.















1. Ensure that the installation surface is solid enough to hold the charger. It is recommended that the wall have a bearing capacity of at least 100 kg.
2. Ensure that the wall is flat and reserve sufficient space around the installation position to ensure good ventilation.
3. Ensure that the wall is larger than the rear cover of the charger.
4. When installing the product, use a screwdriver with a proper torque to tighten the screws.
5. When routing power cables, ensure that there is no coiling or twisting.
6. Do not join or weld power cables. If necessary, use a longer cable.



1. Do not use third-party cables or adapters.
2. Do not drop, squeeze, or pierce the product to avoid device faults.
3. Before charging your electric or hybrid vehicle, turn off the car.
4. Radio waves generated by the product may affect normal operation of implanted medical appliances or personal medical appliances, such as the pacemakers, cochlear implants, and hearing aids. Consult the manufacturer of your medical equipment for more information.
5. Do not install or use the product in an environment with strong magnetic fields or near a wireless transmitter.

2. Accessories

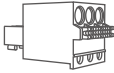
Item	Icon	Quantity	Function
Cord end terminal		12	To crimp the AC input wires
L-shaped wrench		1	To loosen the back plate from core box
Cable clip		2	To secure the AC input cable
Cable holder		2 (cable only)	To hang the charging cable
Positioning diagram		1	Positioning on the wall to drill holes
RFID card		4	To swipe card to start charging
Cable gland		1	To seal the ends of cables and secure them to enclosure
Wall plug & Screw		6 (cable only)	To fasten the cable holders
M4*16 screw		4	To fasten the cable clip
Cable rubber cover		2	To seal the ends of cables and secure them to enclosure
Anchor bolt		4	To secure the back plate to the wall
QR code sticker		4	Pasted on the charger, and users can scan the code to charge EV
RS485 cable terminal		2	Connected to the RS485 wires, then plugged into the port

! When you receive the product, please ensure that the accessories are complete; if any are missing, please contact us.

3. Product overview

Socket

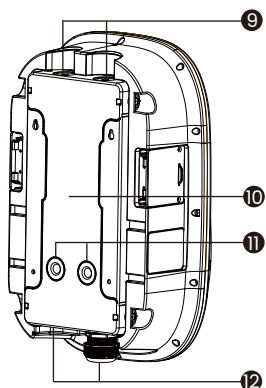
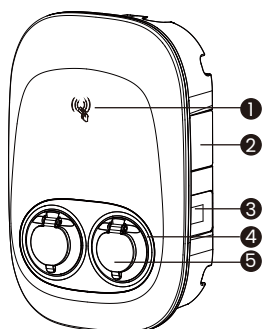

Cable

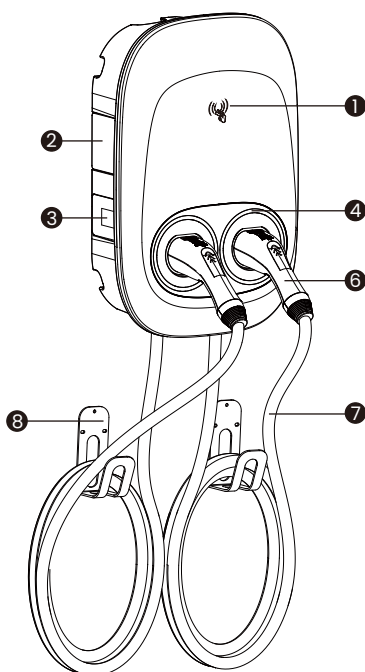

1. RFID card sensor
2. RCBO
3. Meter
4. Indicator
5. Charging socket
6. Charging connector

7. Charging cable
8. Cable holder
9. Top cable inlet
10. Back plate
11. Rear cable inlet
12. Bottom cable inlet



The rear of the socket and the cable versions are exactly the same.

Product Dimensions

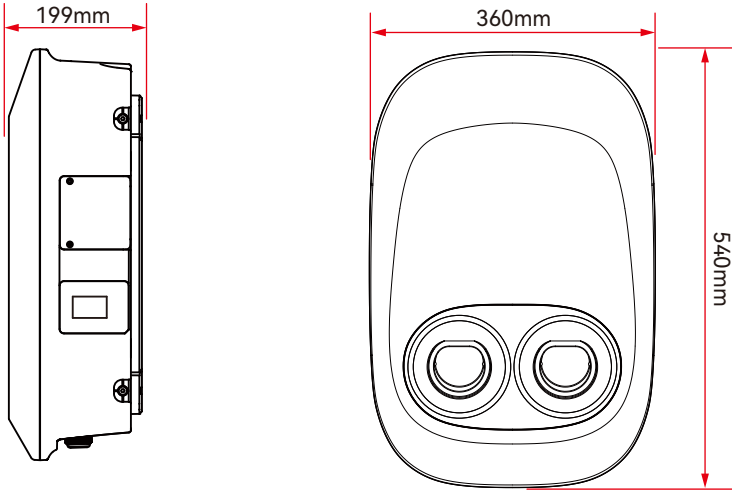

Model Classification

Model Number	Specification
AC022K-BE-42D	Nano Dual Charger - 1x22kW / 2x11kW Type 2 socket without MID meter
AC022K-BE-44D	Nano Dual Charger - 1x22kW / 2x11kW Type 2 socket with MID meter
AC022K-AE-42D	Nano Dual Charger - 1x22kW / 2x11kW Type 2 cable without MID meter
AC022K-AE-44D	Nano Dual Charger - 1x22kW / 2x11kW Type 2 cable with MID meter

Specifications

Input	Power Supply	3P + N + PE
	Rated Voltage	400V AC
	Rated Current	32A
	Frequency	50/60Hz
Output	Output Voltage	400V AC
	Rated Current	1*32A / 2*16A
	Rated Power	1*22kW / 2*11kw
User Interface	LED Indicator	Green/Yellow/Red
	RFID Reader	Support
	Start Mode	Plug& Play/RFID Card /App
	Charging Mode	Mode 3
Communication	Wi-Fi	Wi-Fi 802.11 b/g/n 2.4 GHz (2412-2472 MHz)
	4G	4G LTE Cat-1 LTE FDD: B1/B3/B5/B7/B8/B20/B28 LTE TDD: B38/40/41
	Ethernet	Yes
	Bluetooth	Bluetooth Low Energy (BLE 4.1) 2402-2480 MHz (for installer configuration purposes)
	OCPP	OCPP1.6 Json(OCPP2.0 Upgradable)
Safety	RCD	30mA AC +6mA DC
	RCBO	40A Type A
	Ingress Protection	IP54
	Impact Protection	IK10
	Electrical Protection	Over current protection Residual current protection Short circuit protection Surge protection Over/Under voltage protection Over/Under frequency protection Over temperature protection
	EMC Class	Class B
	Type of Protection Against Electric Shock	Class I equipment

Working Environment	Installation	Wall-mounted/ Pedestal-mounted
	Working Temperature	-30°C to +50°C
	Working Humidity	5% to 95 %
	Working Altitude	< 2000m
	Applicable Scenario	Indoor /Outdoor
	Pollution Degree	3
	Grounding System Support	TN, TT, IT
Certification	Safety Compliance (LVD)	EN IEC 61851-1: 2019
	EMC Compliance	EN IEC 61851-21-2: 2021
	RF& Health	EN 300 328 V2.2.2:2019
		EN 300 330 V2.1.1:2017
		EN 301 489-1 V2.2.3:2019
EN 301 489-3 V2.1.1:2019		
EN 301 489-17 V3.2.0:2017		
EN 62311:2020		
EN 301 489-1 V2.2.3		
EN 301 908-13 V13.2.1		
EN 301 489-52 V1.2.1		
RoHS	2011/65/EU	
	IEC 62321	
REACH	1907/2006, REACH etc. (Amendment) Regulations 2021	

4. Installation

! Before the installation, ensure that:

- The charger power is within the allowed load range of the place.
- Cables and RCBOs meet the installation and usage requirements.
- If the AC input power cable exposed to the outdoor environment is 3m or longer, consult the local installer. You are advised to install a surge protective device (SPD) at the upstream of the charger's RCBO.
- A network cable that is long enough is prepared if the charger is connected to a wired network.
- The installation area should be covered by a wireless network if the charger is connected to the network through WiFi.
- The EV charging connector shall be located at a height between 0.5 and 1.5m above ground.

Prepare AC input cable

Cable type	Operating current	Cross-sectional area
AC input power cable	32A	16~25mm ²













! To facilitate cabling, aluminum wires and solid copper wires are not recommended.

Prepare network cable

Cable type	Specification
RJ45 network cable	Cat 5e or higher, CSA: 0.2 ~0.25mm ²

! RJ45 network cable is required only when the charger is connected to a wired network.

Prepare tools

Tool	Icon	Function	Tool	Icon	Function
Tape ruler		Measure the installation height	Marker		Make marks on the wall
Electric screwdriver		Fasten the screws	Wire stripper		Strip the cable and wire
Hammer		Drive the wall plugs into the wall	Electric drill		Drill holes on the wall
Wire stripper		Strip the wire	Adjustable spanner		Fasten the gland
Multimeter		Check the voltage and current	Crystal crimping pliers		Clamp the RJ45 connector
Level		Keep the charger level	Hydraulic clamp		Clamp cord end terminal

Installation procedure

1 Remove the back plate

Separate the back plate from the core box by loosening the four screws on both sides of the charger.

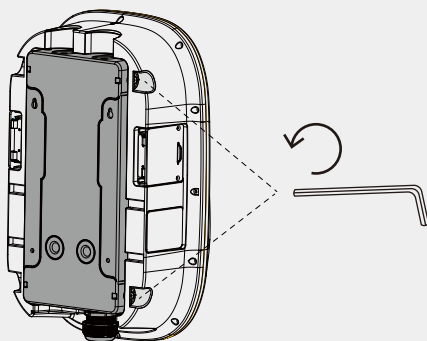

2 Install back plate

- 1). Place the positioning template diagram on the wall and make marks based on the holes in the diagram.
- 2). Drill four holes at the marks.
- 3). Drive anchor bolts into the holes.

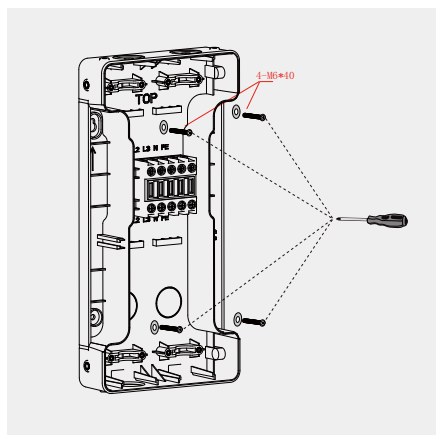
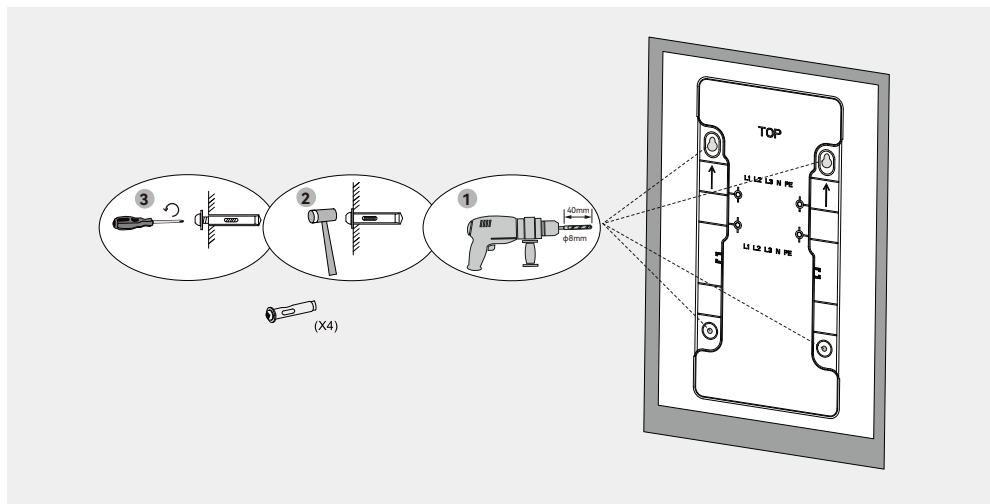

- 4). Align the mounting holes in the back plate with the holes on the wall, then secure the back plate onto the wall with anchor bolt.

3 Cabling in the back plate

As shown below, the cable can be routed into the charger from Top, Rear and Bottom.

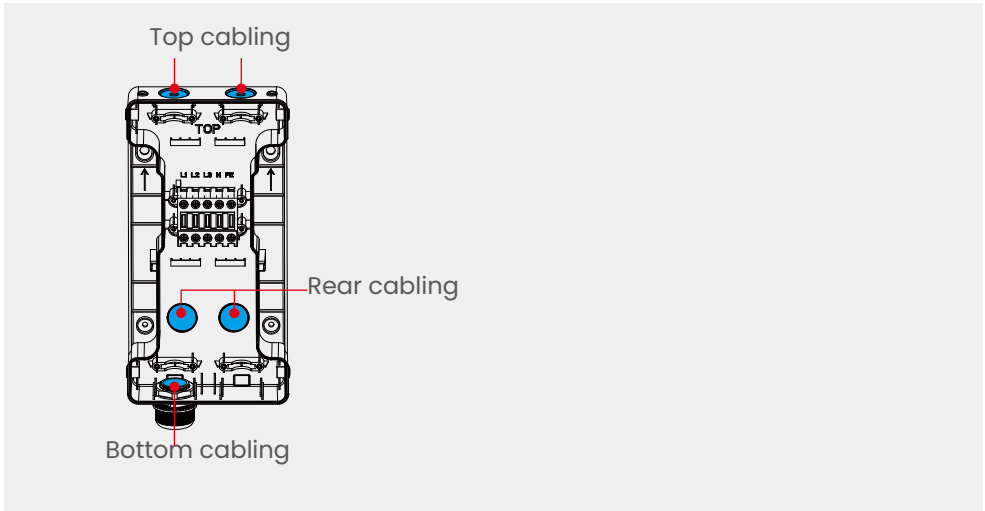

The following cables comply with the IEC 60446 standard. Cable colors may vary according to different regions.

TN and TT systems are configured with neutral conductors. IT systems do not have neutral conductors.

In addition to conventional wiring, IT system requires the L2 conductor and neutral conductor to be short-circuited.

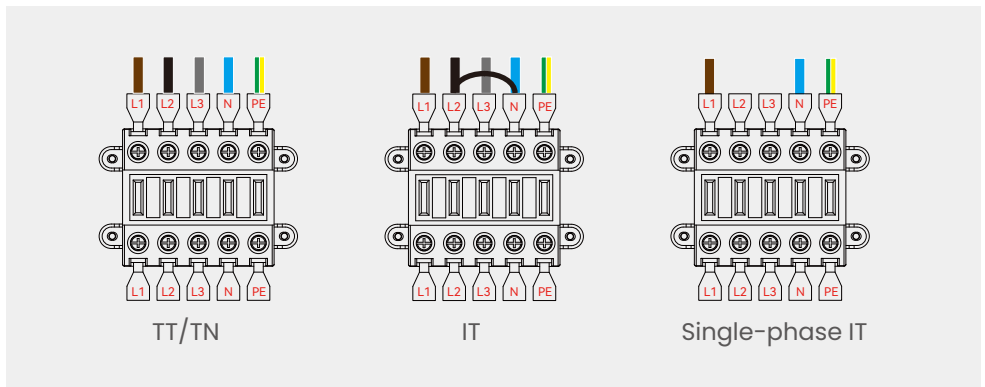

4 Power cable cascade connection

Method 1: The power cable enters from one terminal and exits from another.

This wiring method requires a current of less than 100A, which means you can only connect three chargers together; if you need to connect more than three, the load balance is required.

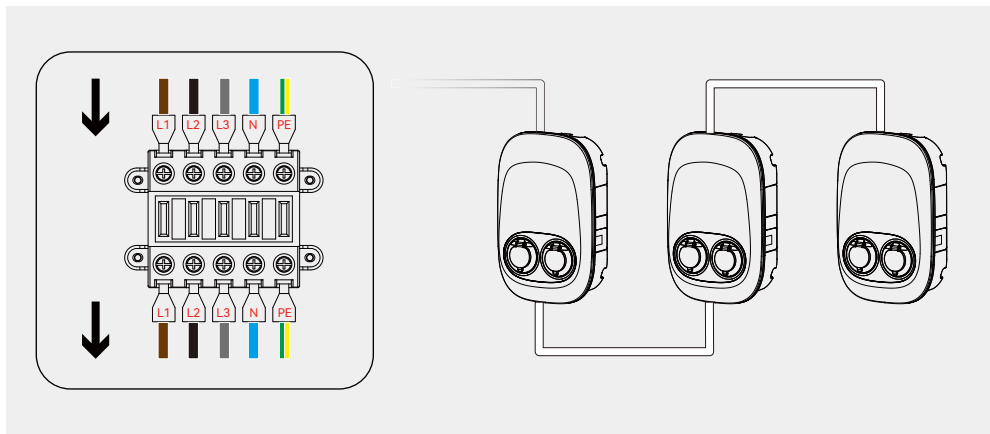

Method 2: The power cable enters and exits through the same terminal.

This wiring method has no current magnitude constraints; however, if you wish to connect more charger, you will need a wire with a larger cross section area, and you must also consider if the terminal port can be inserted into such a wire.

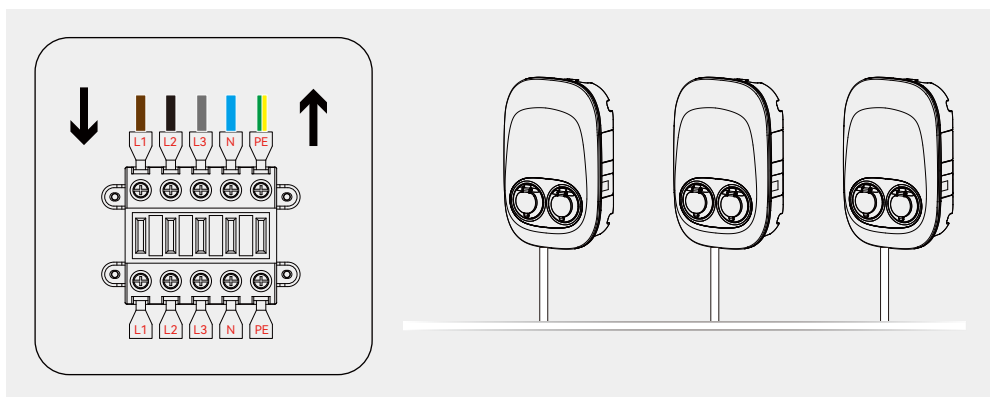

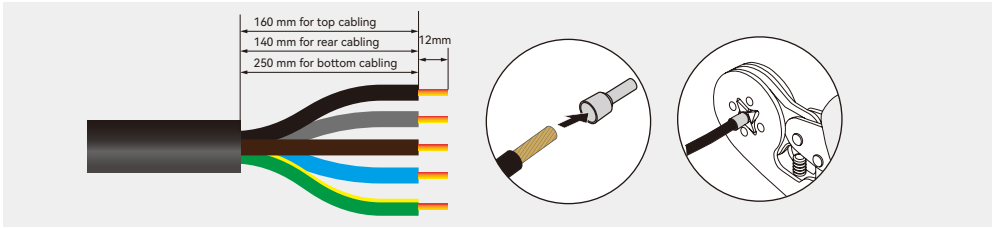

- **Use gland to squeeze the power cable**

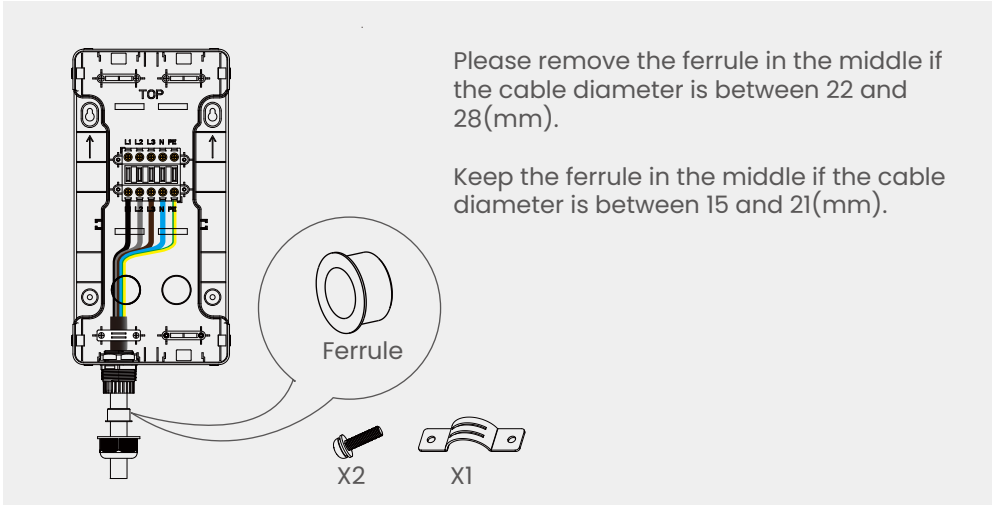

- **Use cable rubber cover to squeeze the power cable**

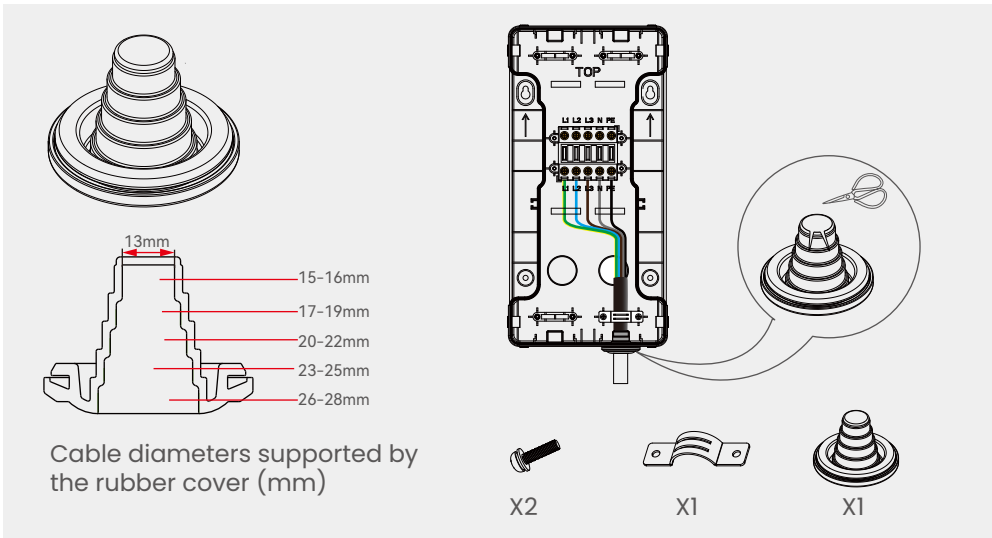

5 Connecting communications cable & Insert 4G card

Loosen the network cable gland and remove the rubber stoppers as needed.
Pass the cable through the holes and connect the connector.

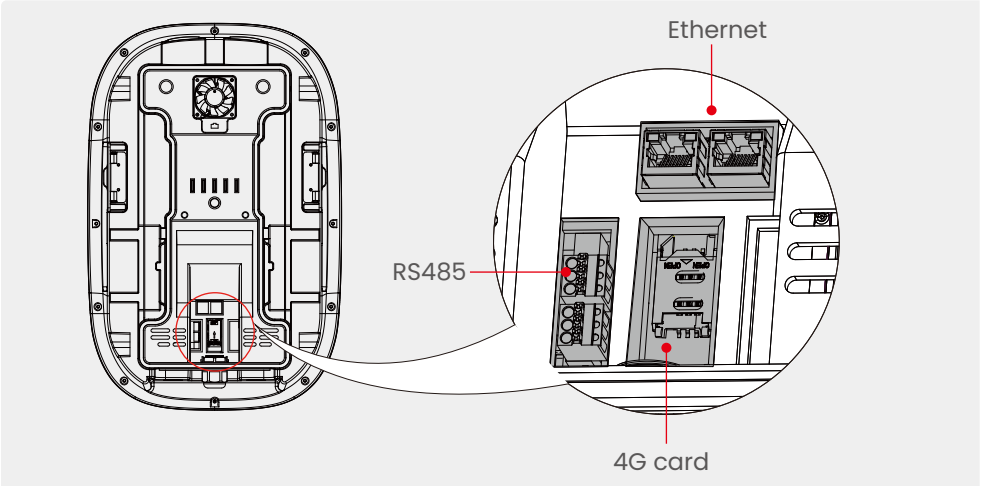
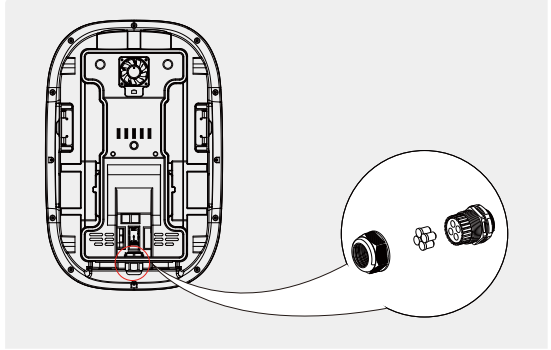

Connect RS485 cable

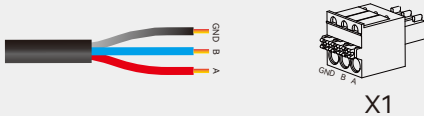

Insert the SIM card

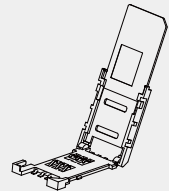

Connect Ethernet cable

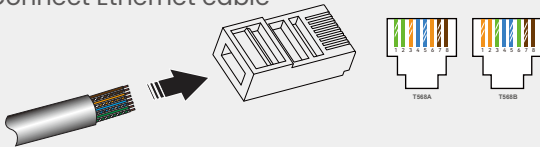

Ethernet cable cascade connection

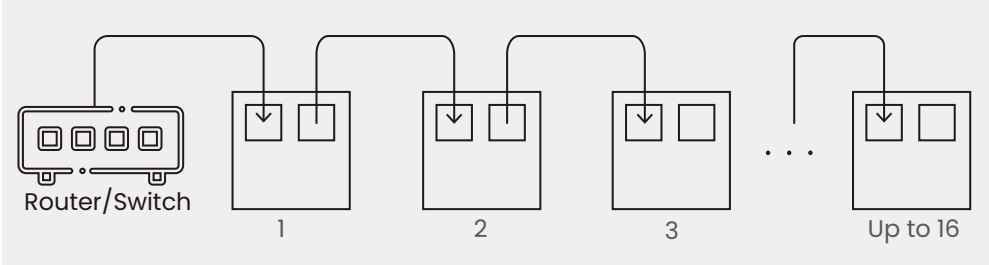

RS485 cable cascade connection

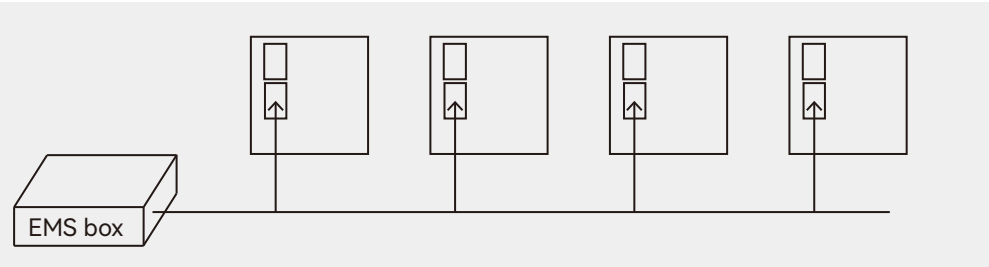

! Energy management system (EMS) is the proactive and systematic monitoring, control, and optimization of an organization's energy consumption to conserve use and decrease energy costs.

6 Completing the installation

- 1). Align the core box with back plate, and push the core box backwards.
- 2). Tighten the screws at the both sides.

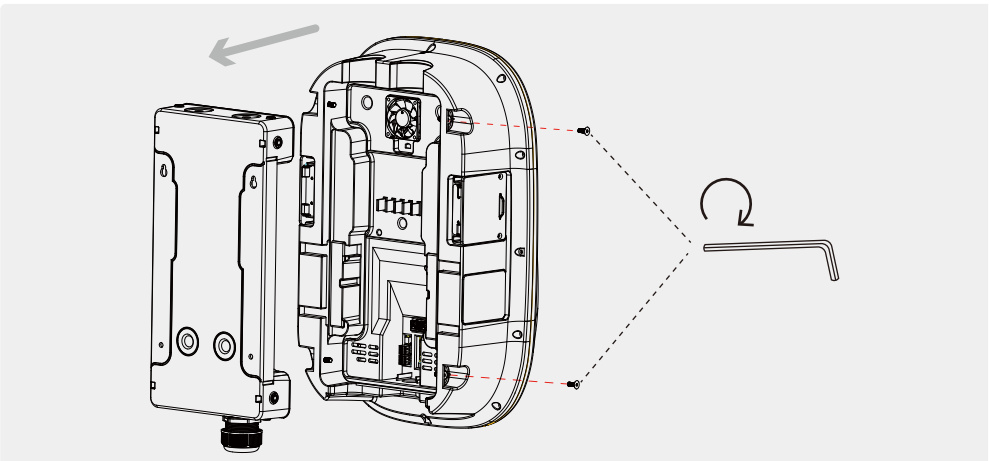

5. Configure network for the charger

You need to configure the network for the charger so that it can communicate with the cloud platform.

Decide what internet connection should be used for the installation. There are three types of internet connection that is possible to use for installation:

- Local WiFi connection from the building where the installation is setup.
- Built-in 4G/LTE module, support insert 4G SIM card.
- Ethernet cable from the router/switch.



The AP mode, which is similar to a local area network, operates the internet locally between you mobile phone and charger.

Log in

1. Set your phone to airplane mode and make sure that the WLAN is turned on.
2. Restart the power supply of the charger to activate the hotspot (the hotspot remains available for 15 minutes only).
3. Locate the charger's Wi-Fi hotspot (wifi name: the serial number of the charger) in your phone's Wi-Fi list.
4. Enter the password to connect the charger to your phone (a dedicated password is 8-digit depending on the SN of the charger which is case sensitive and can be found on the last page of this manual).
5. To access the Login page of AP mode, enter the IP address 192.168.4.1 in a browser, followed by the 4-digit network password: a PIN number*, which can be found on the RCBO and on the last page of this manual.

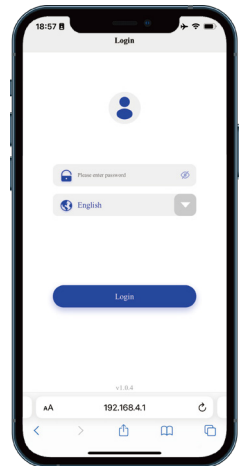

For PIN code, you will be prompted to change it after logging in. If you change the PIN code but forget it later, please press the reset button on RCBO to return the PIN code to the initial value.

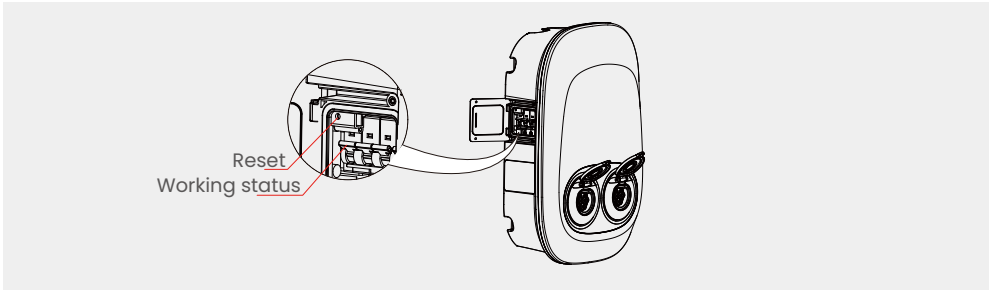

! Your charger will automatically restart once the network configuration is complete, ending communication between your phone and the charger. At this point, your phone may automatically join other Wi-Fi hotspots, preventing you from accessing the network configuration page. As a result, before accessing the network configuration page, please ensure that your phone is connected to the Wi-Fi hotspot of the charger.

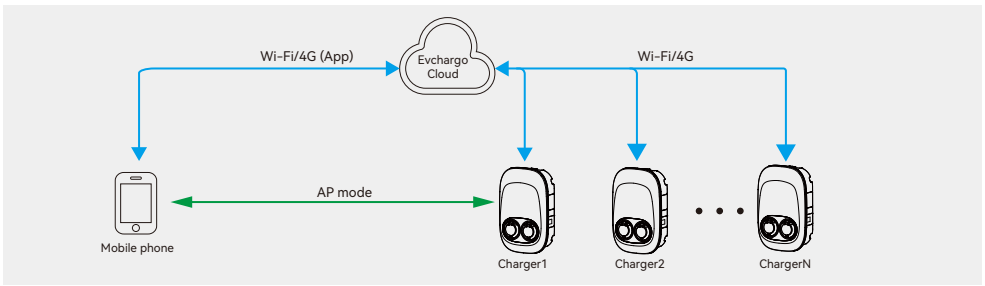

Communications via 4G or wifi

Use Wi-Fi for communication

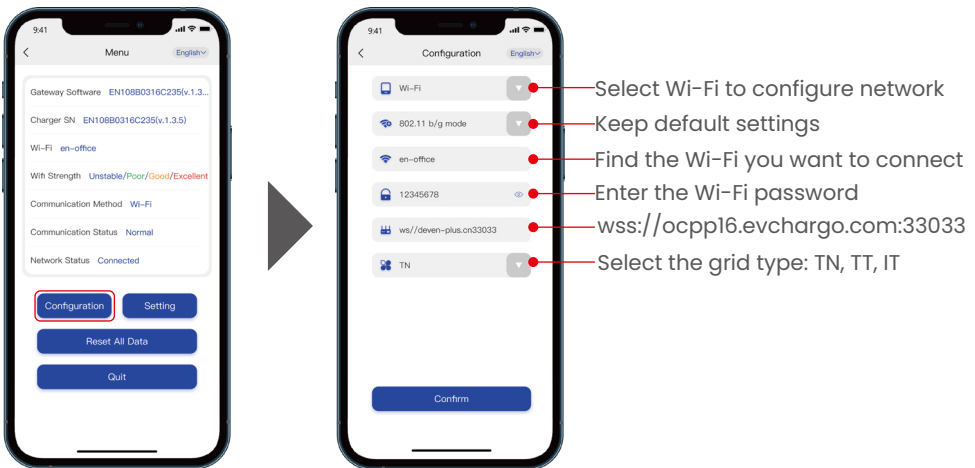

wss://ocpp16.evcharge.com:33033 is an address that connects your charger to a cloud management platform. If you want to connect your charger to a 3rd party's platform, you can enter the URL of the 3rd party platform.



If you select the IT system, you need to TURN ON the three-phase charging.

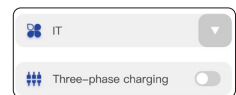

Use 4G for communication

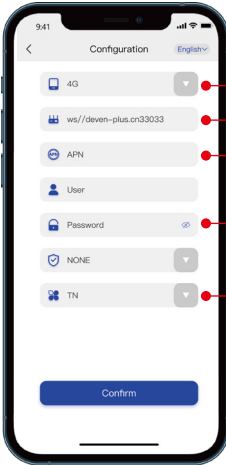

- Select 4G to configure network
- ws://ocpp16.evcharge.com:33033
- Obtain the APN from the 4G network provider
- Keep default settings
- Select grid type TN, TT, IT

Use Ethernet for communication

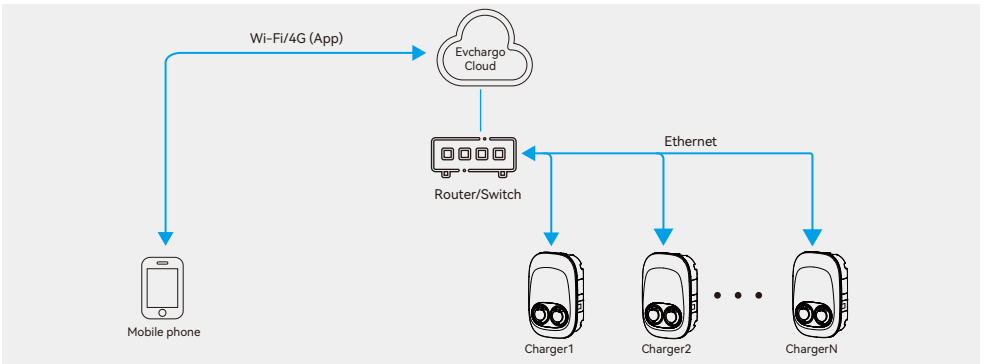

Communication via Ethernet



- Select Ethernet to configure network
- ws://ocpp16.evcharge.com:33033
- Select grid type TN, TT, IT

6. Evcharge cloud platform

Configuring network only allows your charger to communicate with cloud platform. You also need to configure relevant information on the platform.

Evcharge Cloud is a cloud platform for business operators to meet the needs of charging stations, charger monitoring and management, as well as smart and efficient operations and maintenance.

If you are a charger operator, we will email you an account number and password for the platform after you purchase our charger and choose to use our platform. Please use the account number and password to log into the platform and scan QR code below to learn more about the platform operation.



Evcharge Cloud instructions

7. App installation

If you use the charger in a private home scenario, you can use our App to control the charging session.

Download and install the latest app on your smartphone.

Follow the instructions on the app or scan the App instruction's QR code to complete wizard settings and parameter settings.



App download



App instructions

8. Web-based payment

The accessory bag includes four stickers with QR codes on them. You can paste the sticker on the outer surface of the charger so that the user can notice it. If you have the Evcharge App installed, scanning the code will take you to the App. If not, it will take you to the charging web page. In this way, you can control the charging session and make payment on-line. Scan the QR code below for instructions.



Instructions

9. Indicator

Indicator color	Indicator status	Charger status
Green	Steady green	Idle (default)/swiping card with charging connector not plugged, sounds a "beep" signal three times
	Cycle: flashing green twice (on for 200ms and off for 1000ms), then off for 3000ms	Charger started successfully, and wait for EV's feedback
	Cycle: flashing green five times (on for 200ms and off for 1000ms), then off for 3000ms	Charging connector plugged
	Fades in and out at intervals of 1s	Charging in progress
	Cycle: flashing green (on for 1s and off for 3s)	Charging ended
Yellow	Steady yellow	Warnings
	Cycle: flashing yellow (on for 2000ms and off for 2000ms)	Charging connector has been reserved (occupied)
	Cycle: flashing yellow five times (on for 200ms and off for 1000ms), then off for 3000ms.	Insufficient power allocated, charging suspended
	Cycle: flashing yellow for up to five times (on for 100ms and off for 100ms).	Successfully card swiping
Red	Flashing red/Steady red	Faulty
White	Steady white	Charging connector disabled
	Cycle: flashing white (on for 1000ms and off for 1000ms)	Self-test upon power on
	Cycle: flashing white five times (on for 2000ms and off for 1000ms), then off for 3000ms.	Firmware upgrading

10. Troubleshooting

Fault	Indicator status
Warning for grounding	Steady yellow
Relay adhesion	Steady red
Leakage current	Cycle: flashing red once then off for 3s
CP fault	Cycle: flashing red twice then off for 3s
Over current	Cycle: flashing red three times then off for 3s
Input wires are connected reversely	Cycle: flashing red four times then off for 3s
Leakage current loop is abnormal	Cycle: flashing red five times then off for 3s
Input terminals over temperature	Cycle: flashing red six times then off for 3s
Relay over temperature	Cycle: flashing red seven times then off for 3s
Over/under voltage	Cycle: stay yellow for 2s then flash red once then off for 3s
Over/under frequency	Cycle: stay yellow for 2s then flash red twice then off for 3s
Meter communication is abnormal	Cycle: stay yellow for 2s then flash red three times then off for 3s
Smart Meter communication is abnormal	Cycle: stay yellow for 2s then flash red four times then off for 3s
CT fault	Cycle: stay yellow for 2s then flash red five times then off for 3s
Charging connector lock abnormal	Cycle: stay yellow for 2s then flash red six times then off for 3s
Charging connector current abnormal	Cycle: stay yellow for 2s then flash red Seven times then off for 3s

11. Load balancing

Operating a charge station requires a power source (e.g. office building) to carry the total capacity of these chargers. Load balancing distributes the available capacity proportionally over all active chargers. In doing so, optimal charging is provided to all electric vehicles at your location, within the limits of your charge stations' capacity.

For more load balancing information, please scan the QR code below:



Load balancing

12. Routine maintenance

- Chargers do not need special maintenance. You are advised to check and clean the enclosure of the charger and accessories such as the charging connector every six months.
- Check whether the charger and cables are damaged.
- Use a dry cloth to clean the surface of the charger. Do not spray water directly on the charger.



Do not use corrosive cleaners, glass cleaners, or organic solvents.

13. Storage and transportation

Chargers should be transported in the original packages. Do not place other objects on the top of the charger.

Before transportation, store the product in a clean, dry, and well ventilated place with a relative humidity of not more than 80% and free from corrosive gases. The environmental specifications for storage and transportation shall not go beyond those specified in the Technical Specifications.

14. Disassembly

Only authorized and qualified electricians are allowed to disassemble the product. Power off the charger before disassembling it. Disassemble a charger in the reverse order of installation.

15. Disposal/Scrapping

The product should be disposed of at recycling points for electronic equipment. Dispose of the product in a correct and environmental friendly manner in compliance with local laws and regulations.

Electronic devices cannot be disposed of as household waste.

PIN CODE